



Air Conditioning & Heating

Submittal Data Sheet

Project Name:		Approval:	
Location:		Date:	
Engineer:		Construction:	
Submitted to:		Unit #:	
Submitted by:		Drawing #:	
Reference:			

Code	
Indoor unit code	
Outdoor unit code	
Model	
Indoor unit model	MSH123E21AXAA
Outdoor unit model	MSH123E21MCAA



PERFORMANCE DATA

Power supply	Ph-V-Hz	#REF!
Cooling		
Capacity	Btu/h	12000
Input	W	923
Rated current	A	4.1
EER	Btu/w	13
SEER	Btu/w	21.5

Heating at 47

Capacity	Btu/h	12000
Input	W	1085
Rated current	A	4.72
COP	W/W	3.24
HSPF4		9.8
HSPF5		7.7

Electrical

MINIMUM CIRCUIT AMPACITY	A	12
MAX. FUSE	A	15
Connection wiring		16*4 AWG

Compressor

Model		ASM98D32UFZ
Type		ROTARY
Brand		GMCC
Capacity	Btu/h	-
Input	W	800
Rated current(RLA)	A	6.8
Locked rotor Amp(LRA)	A	---
Thermal protector		---
Thermal protector position		---
Refrigerant oil/oil charge	ml	ESTER OIL VG74

SYSTEM DATA

Design pressure	PSIG	-
Refrigerant type	oz	R410A/40.6
Refrigerant precharge	ft	25
Additional charge per ft.	oz	0.16
Liquid side/ Gas side	mm(in)	(1/4 - 1/2)
Max. refrigerant pipe length	ft	82
Max. difference in level	ft.	33

INDOOR UNIT DATA

Indoor fan motor		
Model		ZKFP-20-8-6-7
Type		-
Input		50
RLA	A	0.036
LRA	A	---
Winding Resistance	Ω	---
Capacitor	uF	---
Speed(Hi/Mi/Lo)	r/min	1100/850/700

Air flow & Noise level

Indoor air flow (Hi/Lo)	CFM	306/212/147
Indoor noise level (Hi/Lo)	dB(A)	36.5/32/22.5

Indoor unit

Dimension(W*D*H)	inch	31.57x7.44x11.69
Packing (W*D*H)	inch	34.45X11.22X14.76
Net/Gross weight	lbs.	18.74/24.25

OUTDOOR UNIT DATA

Outdoor fan motor		
Model		ZKFN-34-8-1-3
Type		-
Input		-
RLA	A	0.4
LRA	A	---
Winding Resistance	Ω	---
Capacitor	uF	---
Speed	r/min	800

Air flow & Noise level

Outdoor air flow	CFM	1177
Outdoor noise level	dB(A)	55

Outdoor unit

Dimension(W*D*H)	inch	31.5x13.11x21.81
Packing (W*D*H)	inch	36.22x15.35x24.21
Net/Gross weight	lbs.	80.47/86.20

Operation temperature

Indoor(cooling/ heating)	Deg. F	62~90/32~86
Outdoor(cooling/heating)	Deg. F	-13~122/ -13~86

INDOOR UNIT

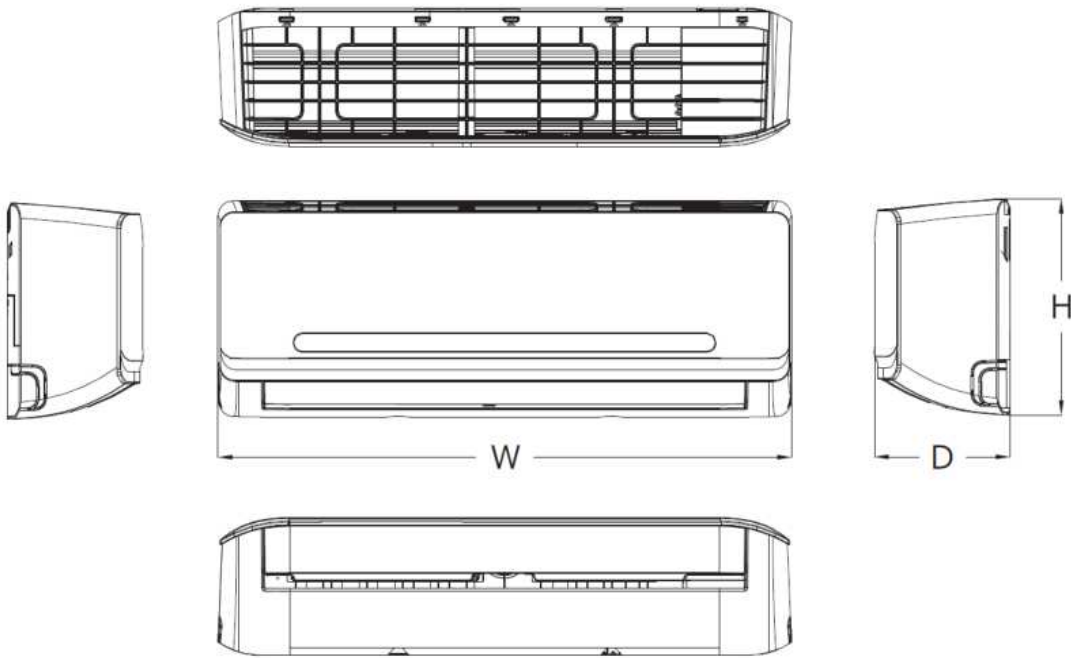

MODEL	W (INCH)	D (INCH)	H (INCH)
MSH123E21AXAA	31.57	7.44	11.69

OUTDOOR UNIT

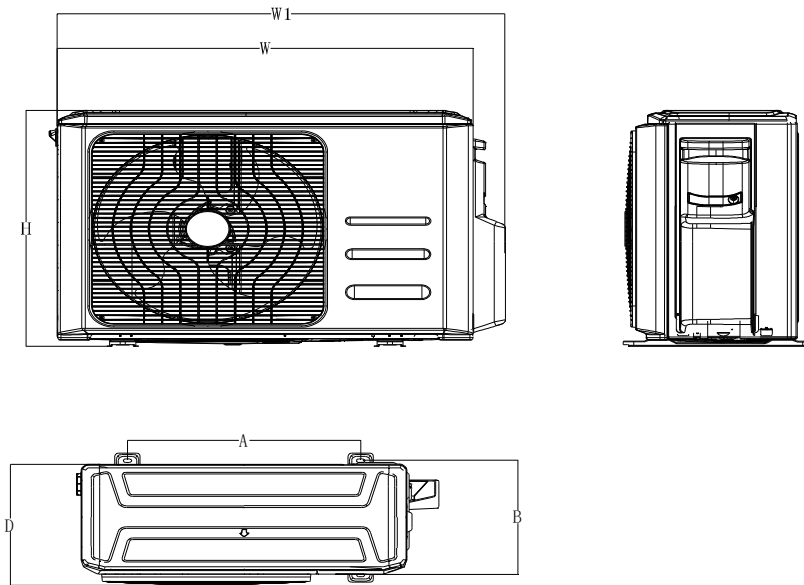

Model	W (inch)	D (inch)	H (inch)	W1 (inch)	A (inch)	B (inch)
MSH123E21MCAA	31.50	13.11	21.81	34.3	20.2	13.4